

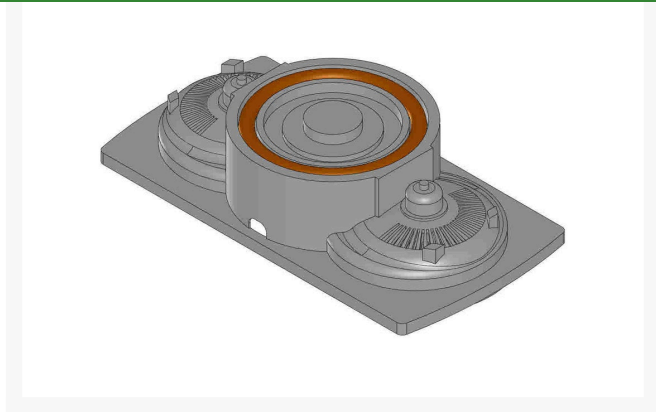

Flojet Check Valve Assembly Kit - Viton

RFJ20914002A



Details

This Duplex II pump incorporates new technology to make it the most advanced and reliable diaphragm pump available. Higher efficiency of the pump is evident in the longer life of the motor pump unit. The newly designed built-in back flow presenter, check valves, bearings and diaphragm make the pump capable of pulling higher dry vacuum. Self-priming up to 8 feet (2.4 m). Can run dry without damage. Heavy-duty ball bearing drive system. Polypropylene w/Viton diaphragm and Viton check valve. 12V, 3/8" FNPT ports, 1.6 GPM, 60 psi switch, Viton valves and diaphragm.

Specifications

Manufacturer	Flojet
--------------	--------

Baber Turf Equipment Co.

Unit 6 / 10 Firth Street Auckland, 2113
09 294 6040

<https://baber.rrproducts.com/>